

(19)



Europäisches Patentamt
European Patent Office
Office européen des brevets



EP 0 855 482 B1

(12)

EUROPEAN PATENT SPECIFICATION

(45) Date of publication and mention
of the grant of the patent:
01.12.1999 Bulletin 1999/48

(51) Int Cl. 6: E04F 15/14, E04F 15/02,
E04F 13/08

(21) Application number: 98106535.2

(22) Date of filing: 29.04.1994

(54) A method for laying and mechanically joining building panels

Methode zum Verlegen und mechanischen Verbinden von Bauplatten

Méthode pour la pose et la jonction d'éléments de construction

(84) Designated Contracting States:
AT BE CH DE DK ES FR GB GR IE IT LI LU MC NL
PT SE

(73) Proprietor: Vålinge Aluminium AB
260 40 Viken (SE)

(30) Priority: 10.05.1993 SE 9301595

(72) Inventor: Pervan, Tony
11452 Stockholm (SE)

(43) Date of publication of application:
29.07.1998 Bulletin 1998/31

(74) Representative: Giver, Sören Bo et al
Awapatent AB,
P.O. Box 5117
200 71 Malmö (SE)

(62) Document number(s) of the earlier application(s) in
accordance with Art. 76 EPC:
94915725.9 / 0 698 162

(56) References cited:
WO-A-93/13280 DE-A- 2 616 077
FR-A- 1 293 043 US-A- 3 538 665

Note: Within nine months from the publication of the mention of the grant of the European patent, any person may give notice to the European Patent Office of opposition to the European patent granted. Notice of opposition shall be filed in a written reasoned statement. It shall not be deemed to have been filed until the opposition fee has been paid. (Art. 99(1) European Patent Convention).

Description

Technical Field

[0001] The invention generally relates to a method of laying two building panels, especially floor panels.

[0002] The joint between the panels to be laid is of the type where the adjacent joint edges together form a first mechanical connection locking the joint edges to each other in a first direction at right angles to the principal plane of the panels, and where a locking device forms a second mechanical connection locking the panels to each other in a second direction parallel to the principal plane and at right angles to the joint edges, the locking device comprising a locking groove which extends parallel to and spaced from the joint edge of one of the panels, and said locking groove being open at the rear side of this one panel.

[0003] The invention is especially well suited for use in joining floor panels, especially thin laminated floors. Thus, the following description of the prior art and of the objects and features of the invention will be focused on this field of use. It should however be emphasised that the invention is useful also for joining ordinary wooden floors as well as other types of building panels, such as wall panels and roof slabs.

Background of the Invention

[0004] A joint of the aforementioned type is known e.g. from SE 450,141. The first mechanical connection is achieved by means of joint edges having tongues and grooves. The locking device for the second mechanical connection comprises two oblique locking grooves, one in the rear side of each panel, and a plurality of spaced-apart spring clips which are distributed along the joint and the legs of which are pressed into the grooves, and which are biased so as to tightly clamp the floor panels together. Such a joining technique is especially useful for joining thick floor panels to form surfaces of a considerable expanse.

[0005] Thin floor panels of a thickness of about 7-10 mm, especially laminated floors, have in a short time taken a substantial share of the market. All thin floor panels employed are laid as "floating floors" without being attached to the supporting structure. As a rule, the dimension of the floor panels is 200 x 1200 mm, and their long and short sides are formed with tongues and grooves. Traditionally, the floor is assembled by applying glue in the groove and forcing the floor panels together. The tongue is then glued in the groove of the other panel. As a rule, a laminated floor consists of an upper decorative wear layer of laminate having a thickness of about 1 mm, an intermediate core of particle board or other board, and a base layer to balance the construction. The core has essentially poorer properties than the laminate, e.g. in respect of hardness and water resistance, but it is nonetheless needed primarily for

providing a groove and tongue for assemblage. This means that the overall thickness must be at least about 7 mm. These known laminated floors using glued tongue-and-groove joints however suffer from several inconveniences.

[0006] First, the requirement of an overall thickness of at least about 7 mm entails an undesirable restraint in connection with the laying of the floor, since it is easier to cope with low thresholds when using thin floor panels, and doors must often be adjusted in height to come clear of the floor laid. Moreover, manufacturing costs are directly linked with the consumption of material.

[0007] Second, the core must be made of moisture-absorbent material to permit using water-based glues when laying the floor. Therefore, it is not possible to make the floors thinner using so-called compact laminate, because of the absence of suitable gluing methods for such non-moisture-absorbent core materials.

[0008] Third, since the laminate layer of the laminated floors is highly wear-resistant, tool wear is a major problem when working the surface in connection with the formation of the tongue.

[0009] Fourth, the strength of the joint, based on a glued tongue-and-groove connection, is restricted by the properties of the core and of the glue as well as by the depth and height of the groove. The laying quality is entirely dependent on the gluing. In the event of poor gluing, the joint will open as a result of the tensile stresses which occur e.g. in connection with a change in air humidity.

[0010] Fifth, laying a floor with glued tongue-and-groove joints is time-consuming, in that glue must be applied to every panel on both the long and short sides thereof.

[0011] Sixth, it is not possible to disassemble a glued floor once laid, without having to break up the joints. Floor panels that have been taken up cannot therefore be used again. This is a drawback particularly in rental houses where the flat concerned must be put back into the initial state of occupancy. Nor can damaged or worn-out panels be replaced without extensive efforts, which would be particularly desirable on public premises and other areas where parts of the floor are subjected to great wear.

[0012] Seventh, known laminated floors are not suited for such use as involves a considerable risk of moisture penetrating down into the moisture-sensitive core.

[0013] Eighth, present-day hard, floating floors require, prior to laying the floor panels on hard subfloors, the laying of a separate underlay of floor board, felt, foam or the like, which is to damp impact sounds and to make the floor more pleasant to walk on. The placement of the underlay is a complicated operation, since the underlay must be placed in edge-to-edge fashion. Different underlays affect the properties of the floor.

[0014] There is thus a strongly-felt need to overcome the above-mentioned drawbacks of the prior art. It is however not possible simply to use the known joining

technique with glued tongues and grooves for very thin floors, e.g. with floor thicknesses of about 3 mm, since a joint based on a tongue-and-groove connection would not be sufficiently strong and practically impossible to produce for such thin floors. Nor are any other known joining techniques usable for such thin floors. Another reason why the making of thin floors from e.g. compact laminate involves problems is the thickness tolerances of the panels, being about 0.2-0.3 mm for a panel thickness of about 3 mm. A 3-mm compact laminate panel having such a thickness tolerance would have, if ground to uniform thickness on its rear side, an unsymmetrical design, entailing the risk of bulging. Moreover, if the panels have different thicknesses, this also means that the joint will be subjected to excessive load.

[0015] Nor is it possible to overcome the above-mentioned problems by using double-adhesive tape or the like on the undersides of the panels, since such a connection catches directly and does not allow for subsequent adjustment of the panels as is the case with ordinary gluing.

[0016] Using U-shaped clips of the type disclosed in the above-mentioned SE 450,141, or similar techniques, to overcome the drawbacks discussed above is no viable alternative either. Especially, biased clips of this type cannot be used for joining panels of such a small thickness as 3 mm. Normally, it is not possible to disassemble the floor panels without having access to their undersides. This known technology relying on clips suffers from the additional drawbacks:

- Subsequent adjustment of the panels in their longitudinal direction is a complicated operation in connection with laying, since the clips urge the panels tightly against each other.
- Floor laying using clips is time-consuming.
- This technique is usable only in those cases where the floor panels are resting on underlying joists with the clips placed therebetween. For thin floors to be laid on a continuous, flat supporting structure, such clips cannot be used.
- The floor panels can be joined together only at their long sides. No clip connection is provided on the short sides.

Technical Problems and Objects of the Invention

[0017] A main object of the invention therefore is to provide a method for joining together building panels, especially floor panels for hard, floating floors, which allows using floor panels of a smaller overall thickness than present-day floor panels.

[0018] A particular object of the invention is to provide a panel-joining system which

- makes it possible in a simple, cheap and rational way to provide a joint between floor panels without requiring the use of glue, especially a joint based

primarily only on mechanical connections between the panels;

- can be used for joining floor panels which have a smaller thickness than present-day laminated floors and which have, because of the use of a different core material, superior properties than present-day floors even at a thickness of 3 mm;
- makes it possible between thin floor panels to provide a joint that eliminates any unevennesses in the joint because of thickness tolerances of the panels;
- allows joining all the edges of the panels;
- reduces tool wear when manufacturing floor panels with hard surface layers;
- allows repeated disassembly and reassembly of a floor previously laid, without causing damage to the panels, while ensuring high laying quality;
- makes it possible to provide moisture-proof floors;
- makes it possible to obviate the need of accurate, separate placement of an underlay before laying the floor panels; and
- considerably cuts the time for joining the panels.

[0019] These and other objects of the invention are achieved by means of a panel-joining system having the features recited in the appended claims.

[0020] Thus, the invention provides a method of laying two building panels, especially floor panels, in which joint:

the adjacent joint edges together form a first mechanical connection locking the joint edges to each other in a first direction at right angles to the principal plane of the panels, and

a locking device arranged on the rear side of the panels forms a second mechanical connection locking the panels to each other in a second direction parallel to the principal plane and at right angles to the joint edges, said locking device comprising a locking groove which extends parallel to and spaced from the joint edge of one of said panels, termed groove panel, and which is open at the rear side of the groove panel, said system being characterised in

that the locking device further comprises a strip integrated with the other of said panels, termed strip panel, said strip extending throughout substantially the entire length of the joint edge of the strip panel and being provided with a locking element projecting from the strip, such that when the panels are joined together, the strip projects on the rear side of the groove panel with its locking element received in the locking groove of the groove panel, that the panels, when joined together, can occupy a relative position in said second direction where a play exists between the locking groove and a locking surface on the locking element that is facing the joint edges and is operative in said second mechanical connection,

that the first and the second mechanical connection both allow mutual displacement of the panels in the direction of the joint edges, and that the second mechanical connection is so conceived as to allow the locking element to leave the locking groove if the groove panel is turned about its joint edge angularly away from the strip.

[0021] The term "rear side" as used above should be considered to comprise any side of the panel located behind/ underneath the front side of the panel. The opening plane of the locking groove of the groove panel can thus be located at a distance from the rear surface of the panel resting on the supporting structure. Moreover, the strip, which in the invention extends throughout substantially the entire length of the joint edge of the strip panel, should be considered to encompass both the case where the strip is a continuous, uninterrupted element, and the case where the "strip" consists in its longitudinal direction of several parts, together covering the main portion of the joint edge.

[0022] It should also be noted (i) that it is the first and the second mechanical connection as such that permit mutual displacement of the panels in the direction of the joint edges, and that (ii) it is the second mechanical connection as such that permits the locking element to leave the locking groove if the groove panel is turned about its joint edge angularly away from the strip. Within the scope of the invention, there may thus exist means, such as glue and mechanical devices, that can counteract or prevent such displacement and/or upward angling.

[0023] The system according to the invention makes it possible to provide concealed, precise locking of both the short and long sides of the panels in hard, thin floors. The floor panels can be quickly and conveniently disassembled in the reverse order of laying without any risk of damage to the panels, ensuring at the same time a high laying quality. The panels can be assembled and disassembled much faster than in present-day systems, and any damaged or worn-out panels can be replaced by taking up and re-laying parts of the floor.

[0024] According to an especially preferred embodiment of the invention, a method is provided which permits precise joining of thin floor panels having, for example, a thickness of the order of 3 mm and which at the same time provides a tolerance-independent smooth top face at the joint. To this end, the strip is mounted in an equalising groove which is countersunk in the rear side of the strip panel and which exhibits an exact, predetermined distance from its bottom to the front side of the strip panel. The part of the strip projecting behind the groove panel engages a corresponding equalising groove, which is countersunk in the rear side of the groove panel and which exhibits the same exact, predetermined distance from its bottom to the front side of the groove panel. The thickness of the strip then is at least so great that the rear side of the strip is flush with,

and preferably projects slightly below the rear side of the panels. In this embodiment, the panels will always rest, in the joint, with their equalising grooves on a strip. This levels out the tolerance and imparts the necessary strength to the joint. The strip transmits horizontal and upwardly-directed forces to the panels and downwardly-directed forces to the existing subfloor.

[0025] Preferably, the strip may consist of a material which is flexible, resilient and strong, and can be sawn. A preferred strip material is sheet aluminium. In an aluminium strip, sufficient strength can be achieved with a strip thickness of the order of 0.5 mm.

[0026] In order to permit taking up previously laid, joined floor panels in a simple way, a preferred embodiment of the invention is characterised in that when the groove panel is pressed against the strip panel in the second direction and is turned angularly away from the strip, the maximum distance between the axis of rotation of the groove panel and the locking surface of the locking groove closest to the joint edges is such that the locking element can leave the locking groove without contacting the locking surface of the locking groove. Such a disassembly can be achieved even if the aforementioned play between the locking groove and the locking surface is not greater than 0.2 mm.

[0027] According to the invention, the locking surface of the locking element is able to provide a sufficient locking function even with very small heights of the locking surface. Efficient locking of 3-mm floor panels can be achieved with a locking surface that is as low as 2 mm. Even a 0.5-mm-high locking surface may provide sufficient locking. The term "locking surface" as used herein relates to the part of the locking element engaging the locking groove to form the second mechanical connection.

[0028] For optimal function of the invention, the strip and the locking element should be formed on the strip panel with high precision. Especially, the locking surface of the locking element should be located at an exact distance from the joint edge of the strip panel.

[0029] Furthermore, the extent of the engagement in the floor panels should be minimised, since it reduces the floor strength.

[0030] By known manufacturing methods, it is possible to produce a strip with a locking pin, for example by extruding aluminium or plastics into a suitable section, which is thereafter glued to the floor panel or is inserted in special grooves. These and all other traditional methods do however not ensure optimum function and an optimum level of economy. To produce the joint system according to the invention, the strip is suitably formed from sheet aluminium, and is mechanically fixed to the strip panel.

[0031] The laying of the panels can be performed by first placing the strip panel on the subfloor and then moving the groove panel with its long side up to the long side of the strip panel, at an angle between the principal plane of the groove panel and the subfloor. When the

joint edges have been brought into engagement with each other to form the first mechanical connection, the groove panel is angled down so as to accommodate the locking element in the locking groove.

[0032] Laying can also be performed by first placing both the strip panel and the groove panel flat on the sub-floor and then joining the panels parallel to their principal planes while bending the strip downwards until the locking element snaps up into the locking groove. This laying technique enables in particular mechanical locking of both the short and long sides of the floor panels. For example, the long sides can be joined together by using the first laying technique with downward angling of the groove panel, while the short sides are subsequently joined together by displacing the groove panel in its longitudinal direction until its short side is pressed on and locked to the short side of an adjacent panel in the same row.

[0033] In connection with their manufacture, the floor panels can be provided with an underlay of e.g. floor board, foam or felt. The underlay should preferably cover the strip such that the joint between the underlays is offset in relation to the joint between the floor panels.

[0034] The above and other features and advantages of the invention will appear from the appended claims and the following description of embodiments of the invention.

[0035] The invention will now be described in more detail hereinbelow with reference to the accompanying drawing Figures.

Description of Drawing Figures

[0036] Figs 1a and 1b schematically show in two stages how two floor panels of different thickness are joined together in floating fashion according to a first embodiment of the invention.

[0037] Figs 2a-c show in three stages a method for mechanically joining two floor panels according to a second embodiment of the invention.

[0038] Figs 3a-c show in three stages another method for mechanically joining the floor panels of Figs 2a-c.

[0039] Figs 4a and 4b show a floor panel according to Figs 2a-c as seen from below and from above, respectively.

[0040] Fig. 5 illustrates in perspective a method for laying and joining floor panels according to a third embodiment of the invention.

[0041] Fig. 6 shows in perspective and from below a first variant for mounting a strip on a floor panel.

[0042] Fig. 7 shows in section a second variant for mounting a strip on a floor panel.

Description of Preferred Embodiments

[0043] Figs 1a and 1b, to which reference is now made, illustrate a first floor panel 1, hereinafter termed strip panel, and a second floor panel 2, hereinafter

termed groove panel. The terms "strip panel" and "groove panel" are merely intended to facilitate the description of the invention, the panels 1, 2 normally being identical in practice. The panels 1 and 2 may be made from compact laminate and may have a thickness of about 3 mm with a thickness tolerance of about ± 0.2 mm. Considering this thickness tolerance, the panels 1, 2 are illustrated with different thicknesses (Fig. 1b), the strip panel 1 having a maximum thickness (3.2 mm) and the groove panel 2 having a minimum thickness (2.8 mm).

[0044] To enable mechanical joining of the panels 1, 2 at opposing joint edges, generally designated 3 and 4, respectively, the panels are provided with grooves and strips as described in the following.

[0045] Reference is now made primarily to Figs 1a and 1b, and secondly to Figs 4a and 4b showing the basic design of the floor panels from below and from above, respectively.

[0046] From the joint edge 3 of the strip panel 1, i.e. the one long side, projects horizontally a flat strip 6 mounted at the factory on the underside of the strip panel 1 and extending throughout the entire joint edge 3. The strip 6, which is made of flexible, resilient sheet aluminium, can be fixed mechanically, by means of glue or in any other suitable way. In Figs 1a and 1b, the strip 6 is glued, while in Figs 4a and 4b it is mounted by means of a mechanical connection, which will be described in more detail hereinbelow.

[0047] Other strip materials can be used, such as sheets of other metals, as well as aluminium or plastics sections. Alternatively, the strip 6 may be integrally formed with the strip panel 1. At any rate, the strip 6 should be integrated with the strip panel 1, i.e. it should not be mounted on the strip panel 1 in connection with laying. As a non-restrictive example, the strip 6 may have a width of about 30 mm and a thickness of about 0.5 mm.

[0048] As appears from Figs 4a and 4b, a similar, although shorter strip 6' is provided also at one short side 3' of the strip panel 1. The shorter strip 6' does however not extend throughout the entire short side 3' but is otherwise identical with the strip 6 and, therefore, is not described in more detail here.

[0049] The edge of the strip 6 facing away from the joint edge 3 is formed with a locking element 8 extended throughout the entire strip 6. The locking element 8 has a locking surface 10 facing the joint edge 3 and having a height of e.g. 0.5 mm. The locking element 8 is so designed that when the floor is being laid and the strip panel 2 of Fig. 1a is pressed with its joint edge 4 against the joint edge 3 of the strip panel 1 and is angled down against the subfloor 12 according to Fig. 1b, it enters a locking groove 14 formed in the underside 16 of the groove panel 2 and extending parallel to and spaced from the joint edge 4. In Fig. 1b, the locking element 8 and the locking groove 14 together form a mechanical connection locking the panels 1, 2 to each other in the

direction designated D2. More specifically, the locking surface 10 of the locking element 8 serves as a stop with respect to the surface of the locking groove 14 closest to the joint edge 4.

[0050] When the panels 1 and 2 are joined together, they can however occupy such a relative position in the direction D2 that there is a small play Δ between the locking surface 10 and the locking groove 14. This mechanical connection in the direction D2 allows mutual displacement of the panels 1, 2 in the direction of the joint, which considerably facilitates the laying and enables joining together the short sides by snap action.

[0051] As appears from Figs 4a and 4b, each panel in the system has a strip 6 at one long side 3 and a locking groove 14 at the other long side 4, as well as a strip 6' at one short side 3' and a locking groove 14' at the other short side 4'.

[0052] Furthermore, the joint edge 3 of the strip panel 1 has in its underside 18 a recess 20 extending throughout the entire joint edge 3 and forming together with the upper face 22 of the strip 6 a laterally open recess 24. The joint edge 4 of the groove panel 2 has in its top side 26 a corresponding recess 28 forming a locking tongue 30 to be accommodated in the recess 24 so as to form a mechanical connection locking the joint edges 3, 4 to each other in the direction designated D1. This connection can be achieved with other designs of the joint edges 3, 4, for example by a bevel thereof such that the joint edge 4 of the groove panel 2 passes obliquely in underneath the joint edge 3 of the strip panel 1 to be locked between that edge and the strip 6.

[0053] The panels 1, 2 can be taken up in the reverse order of laying without causing any damage to the joint, and be laid again.

[0054] The strip 6 is mounted in a tolerance-equalising groove 40 in the underside 18 of the strip panel 1 adjacent the joint edge 3. In this embodiment, the width of the equalising groove 40 is approximately equal to half the width of the strip 6, i.e. about 15 mm. By means of the equalising groove 40, it is ensured that there will always exist between the top side 21 of the panel 1 and the bottom of the groove 40 an exact, predetermined distance E which is slightly smaller than the minimum thickness (2.8 mm) of the floor panels 1, 2. The groove panel 2 has a corresponding tolerance-equalising surface or groove 42 in the underside 16 of the joint edge 4. The distance between the equalising surface 42 and the top side 26 of the groove panel 2 is equal to the aforementioned exact distance E. Further, the thickness of the strip 6 is so chosen that the underside 44 of the strip is situated slightly below the undersides 18 and 16 of the floor panels 1 and 2, respectively. In this manner, the entire joint will rest on the strip 6, and all vertical downwardly-directed forces will be efficiently transmitted to the subfloor 12 without any stresses being exerted on the joint edges 3, 4. Thanks to the provision of the equalising grooves 40, 42, an entirely even joint will be achieved on the top side, despite the thickness toleranc-

es of the panels 1, 2, without having to perform any grinding or the like across the whole panels. Especially, this obviates the risk of damage to the bottom layer of the compact laminate, which might give rise to bulging of the panels.

[0055] Reference is now made to the embodiment of Figs 2a-c showing in a succession substantially the same laying method as in Figs 1a and 1b. The embodiment of Figs 2a-c primarily differs from the embodiment of Figs 1a and 1b in that the strip 6 is mounted on the strip panel 1 by means of a mechanical connection instead of glue. To provide this mechanical connection, illustrated in more detail in Fig. 6, a groove 50 is provided in the underside 18 of the strip panel 1 at a distance from the recess 24. The groove 50 may be formed either as a continuous groove extending throughout the entire length of the panel 1, or as a number of separate grooves. The groove 50 defines, together with the recess 24, a dovetail gripping edge 52, the underside of which exhibits an exact equalising distance E to the top side 21 of the strip panel 1. The aluminium strip 6 has a number of punched and bent tongues 54, as well as one or more lips 56 which are bent round opposite sides of the gripping edge 52 in clamping engagement therewith. This connection is shown in detail from below in the perspective view of Fig. 6.

[0056] Alternatively, a mechanical connection between the strip 6 and the strip panel 1 can be provided as illustrated in Fig. 7 showing in section a cut-away part of the strip panel 1 turned upside down. In Fig. 7, the mechanical connection comprises a dovetail recess 58 in the underside 18 of the strip panel 1, as well as tongues/lips 60 punched and bent from the strip 6 and clamping against opposing inner sides of the recess 58.

[0057] The embodiment of Figs 2a-c is further characterised in that the locking element 8 of the strip 6 is designed as a component bent from the aluminium sheet and having an operative locking surface 10 extending at right angles up from the front side 22 of the strip 6 through a height of e.g. 0.5 mm, and a rounded guide surface 34 facilitating the insertion of the locking element 8 into the locking groove 14 when angling down the groove panel 2 towards the subfloor 12 (Fig. 2b), as well as a portion 36 which is inclined towards the subfloor 12 and which is not operative in the laying method illustrated in Figs 2a-c.

[0058] Further, it can be seen from Figs 2a-c that the joint edge 3 of the strip panel 1 has a lower bevel 70 which cooperates during laying with a corresponding upper bevel 72 of the joint edge 4 of the groove panel 2, such that the panels 1 and 2 are forced to move vertically towards each other when their joint edges 3, 4 are moved up to each other and the panels are pressed together horizontally.

[0059] Preferably, the locking surface 10 is so located relative to the joint edge 3 that when the groove panel 2, starting from the joined position in Fig. 2c, is pressed horizontally in the direction D2 against the strip panel 1

and is turned angularly up from the strip 6, the maximum distance between the axis of rotation A of the groove panel 2 and the locking surface 10 of the locking groove is such that the locking element 8 can leave the locking groove 14 without coming into contact with it.

[0060] Figs 3a-3b show another joining method for mechanically joining together the floor panels of Figs 2a-c. The method illustrated in Figs 3a-c relies on the fact that the strip 6 is resilient and is especially useful for joining together the short sides of floor panels which have already been joined along one long side as illustrated in Figs 2a-c. The method of Figs 3a-c is performed by first placing the two panels 1 and 2 flat on the subfloor 12 and then moving them horizontally towards each other according to Fig. 3b. The inclined portion 36 of the locking element 8 then serves as a guide surface which guides the joint edge 4 of the groove panel 2 up on to the upper side 22 of the strip 6. The strip 6 will then be urged downwards while the locking element 8 is sliding on the equalising surface 42. When the joint edges 3, 4 have been brought into complete engagement with each other horizontally, the locking element 8 will snap into the locking groove 14 (Fig. 3c), thereby providing the same locking as in Fig. 2c. The same locking method can also be used by placing, in the initial position, the joint edge 4 of the groove panel with the equalising groove 42 on the locking element 10 (Fig. 3a). The inclined portion 36 of the locking element 10 then is not operative. This technique thus makes it possible to lock the floor panels mechanically in all directions, and by repeating the laying operations the whole floor can be laid without using any glue.

[0061] The invention is not restricted to the preferred embodiments described above and illustrated in the drawings, but several variants and modifications thereof are conceivable within the scope of the appended claims. The strip 6 can be divided into small sections covering the major part of the joint length. Further, the thickness of the strip 6 may vary throughout its width. All strips, locking grooves, locking elements and recesses are so dimensioned as to enable laying the floor panels with flat top sides in a manner to rest on the strip 6 in the joint. If the floor panels consist of compact laminate and if silicone or any other sealing compound, a rubber strip or any other sealing device is applied prior to laying between the flat projecting part of the strip 6 and the groove panel 2 and/or in the recess 26, a moisture-proof floor is obtained.

[0062] As appears from Fig. 6, an underlay 46, e.g. of floor board, foam or felt, can be mounted on the underside of the panels during the manufacture thereof. In one embodiment, the underlay 46 covers the strip 6 up to the locking element 8, such that the joint between the underlays 46 becomes offset in relation to the joint between the joint edges 3 and 4.

[0063] In the embodiment of Fig. 5, the strip 6 and its locking element 8 are integrally formed with the strip panel 1, the projecting part of the strip 6 thus forming an

extension of the lower part of the joint edge 3. The locking function is the same as in the embodiments described above. On the underside 18 of the strip panel 1, there is provided a separate strip, band or the like 74 extending throughout the entire length of the joint and having, in this embodiment, a width covering approximately the same surface as the separate strip 6 of the previous embodiments. The strip 74 can be provided directly on the rear side 18 or in a recess formed therein (not shown), so that the distance from the front side 21, 26 of the floor to the rear side 76, including the thickness of the strip 74, always is at least equal to the corresponding distance in the panel having the greatest thickness tolerance. The panels 1, 2 will then rest, in the joint, on the strip 74 or only on the undersides 18, 16 of the panels, if these sides are made plane.

[0064] When using a material which does not permit downward bending of the strip 6 or the locking element 8, laying can be performed in the way shown in Fig. 5. A floor panel 2a is moved angled upwardly with its long side 4a into engagement with the long side 3 of a previously laid floor panel 1 while at the same time a third floor panel 2b is moved with its short side 4b' into engagement with the short side 3a' of the upwardly-angled floor panel 2a and is fastened by angling the panel 2b downwards. The panel 2b is then pushed along the short side 3a' of the upwardly-angled floor panel 2a until its long side 4b encounters the long side 3 of the initially-laid panel 1. The two upwardly-angled panels 2a and 2b are therefore angled down on to the subfloor 12 so as to bring about locking.

[0065] By a reverse procedure the panels can be taken up in the reverse order of laying without causing any damage to the joint, and be laid again.

[0066] Several variants of preferred laying methods are conceivable. For example, the strip panel can be inserted under the groove panel, thus enabling the laying of panels in all four directions with respect to the initial position.

Claims

1. A method for laying and mechanically joining rectangular building panels (1, 2) in parallel rows, especially floor panels, said panels (1, 2) being provided with means for mechanically locking together their long edges as well as their short edges in a first direction (D1) at right angles to the principal plane of the panels (1, 2), characterised in that each panel (1, 2), at a rear side thereof, being provided with (i) a locking strip (6, 6') at one long edge (3) and at one short edge (3'), each locking strip (6, 6') being either a separate element connected to the panel or an extension of a lower part of the joint edge (3, 3') and extending throughout substantially the entire length of the corresponding edge (3, 3') and being provided with a locking element (8) pro-

jecting from the strip (6, 6'), and (ii) a locking groove (14, 14') at an opposite long edge (4) and at an opposite short edge (4') for receiving a locking element (8) of an adjacent panel, each locking groove (14, 14') extending parallel to and spaced from the corresponding edge (4, 4') and being open at a rear side of the panel; and in that said method includes the following two main locking steps S1 and S2 for laying a new panel:

S1: mechanically connecting a long edge (4 or 3) of the new panel to a long edge (3 or 4) of a previously laid first panel in a first row in such a way that the new panel and the first panel, as a result of said first main locking step S1, are mechanically locked to each other in said first direction (D1) as well as in a second direction (D2) parallel to said principal plane and at right angles to the locked long edges (3, 4), wherein said first main locking step S1 to this end includes

either:

- the substep of placing the new panel in a second row adjacent to said first row with the long edge (4) of the new panel provided with a locking groove (14) being placed upon and in contact with a locking strip (6) at the adjacent long edge (3) of the first panel, while holding the new panel at an angle relative to a principal plane of the first panel and at a distance from its final longitudinal position relative to a previously laid second panel in said second row, and
- the substep of subsequently angling down the new panel so as to accommodate the locking element (8) of said strip (6) of the first panel in said locking groove (14) of the new panel,

or

- the substep of placing the new panel in a second row adjacent to said first row with the locking strip (6) being provided at a long edge (3) of the new panel being inserted under the adjacent long edge (4) of the first panel being provided with a locking groove (14), while holding the new panel at an angle relative to a principal plane of the first panel and at a distance from its final longitudinal position relative to a previously laid second panel in said second row, and
- the substep of subsequently angling

down the new panel so as to accommodate the locking element (8) of said strip (6) of the new panel in said locking groove (14) of the first panel,

and

S2 mechanically connecting a short edge of the new panel to a short edge of said previously laid second panel in the second row in such a way that the new panel and the second panel, as a result of said second main locking step S2, are mechanically locked to each other at said short edges (3', 4') in said first direction (D1) as well as in a third direction (D3) parallel to said principal plane and at right angles to the short edges (3', 4'), wherein said second main locking step S2 is performed by a linear displacement of the new panel in its longitudinal direction relative to the first panel towards said final longitudinal position until the locking element (8) of the strip (6') at one (4') of the short edges is received in the locking groove (14') at the other one (4') of the short edges, whereby the new panel, in its final laid position, is mechanically connected in two direction (D1, D2) at its long edge to the first panel and in two direction (D1, D3) at its short edge to the second panel.

2. A method as claimed in claim 1, wherein, as a result of said linear displacement of the new panel, the locking strip (6') located at the short edges (3', 4') to be locked together is bent downwards until the locking element (8) snaps up into the locking groove (14').
3. A method as claimed in claim 1 or 2, wherein the short edge (4') of the new panel to be locked to the short edge (3') of the second panel presents a locking groove (14') for engagement with a locking element (8) of the second panel.
4. A method as claimed in claim 3, wherein the new panel is angled down into a position where the end portion of the new panel facing the second panel is placed upon and in contact with the locking strip (6') at the short edge (3') of the second panel.
5. A method as claimed in claim 1 or 2, wherein the short edge (3') of the new panel to be locked to the short edge (4') of the second panel presents a locking strip (6') with a locking element (8) for engagement with a locking groove (14') of the second panel.
6. A method as claimed in any one of claims 1-5, wherein said substep of angling down the new pan-

el is performed while holding an upper corner part of the long edge of the new panel in contact with an upper corner part of the long edge of the first panel.

7. A method according to any one of claims 1-6, wherein the new panel, after having been laid and mechanically joined to the first and to the second panel, can be taken up by angling the new panel and the second panel together upwards in relation to the first panel and subsequently loosening the new panel from the second panel by angling and/or linear displacing the new panel in relation to the second panel. 5 10
8. A method as claimed in claim 7, wherein said step of angling the new panel and the second panel together in relation to the first panel can be performed while holding an upper corner part of the long edge of the new panel in contact with an upper corner part of the long edge of the first panel. 15 20

Patentansprüche

1. Verfahren zum Verlegen und mechanischen Verbinden von rechteckigen Gebäudeplatten (1, 2) in parallelen Reihen, insbesondere vom Bodenplatten, wobei die Platten (1, 2) mit Einrichtungen versehen sind, um ihre langen Kanten sowie ihre kurzen Kanten in einer ersten Richtung (D1) unter rechten Winkeln zu der Hauptebene der Platten (1, 2) aneinander zu verriegeln, **dadurch gekennzeichnet**, daß jede Platte (1, 2) auf ihrer Rückseite mit (i) einem Verriegelungsstreifen (6, 6') an einer langen Kante (3) und an einer kurzen Kante (3') versehen ist, wobei jeder Verriegelungsstreifen (6, 6'), entweder ein getrenntes Element ist, das mit der Platte verbunden ist, oder eine Fortsetzung eines unteren Teils der Verbindungskante (3, 3') ist und sich im wesentlichen über die gesamte Länge der entsprechenden Kante (3, 3') erstreckt und mit einem Verriegelungselement (8) versehen ist, das von dem Streifen (6, 6') hervorsteht, und (ii) mit einer Verriegelungsnut (14, 14') an einer gegenüberliegenden, langen Kante (4) und an einer gegenüberliegenden, kurzen Kante (4') zur Aufnahme eines Verriegelungselements (8) einer benachbarten Platte, wobei sich jede Verriegelungsnut (14, 14') parallel zu und mit Abstand von der entsprechenden Kante (4, 4') erstreckt und auf der Rückseite der Platte offen ist; und daß das Verfahren die folgenden zwei Hauptverriegelungsschritte S1 und S2 zum Verlegen einer neuen Platte umfaßt: 25 30 35 40 45 50
- S1: mechanisches Verbinden einer langen Kante (4 oder 3) der neuen Platte mit einer langen Kante (3 oder 4) einer vorhergehend verlegten, ersten Platte in einer ersten Reihe derart, 55

daß die neue Platte und die erste Platte als Ergebnis des ersten Hauptverriegelungsschritts S1 mechanisch miteinander in der ersten Richtung (D1) sowie in einer zweiten Richtung (D2) parallel zu der Hauptebene und unter rechten Winkeln zu den verriegelten, langen Kanten (3, 4) verriegelt werden, wobei der erste Hauptverriegelungsschritt S1 hierfür umfaßt entweder:

den Unterschritt, die neue Platte in einer zweiten Reihe, der ersten Reihe benachbart, anzuordnen, wobei die lange Kante (4) der neuen Platte, die mit einer Verriegelungsnut (14) versehen ist, die auf und in Berührung mit einem Verriegelungsstreifen (6) an der benachbarten, langen Kante (3) der ersten Platte angeordnet wird, während die neue Platte unter einem Winkel in bezug auf eine Hauptebene der ersten Platte und mit einem Abstand von ihrer endgültigen Längsposition in bezug auf eine vorhergehend verlegte, zweite Platte in der zweiten Reihe gehalten wird, und

den Unterschritt, nachfolgend die neue Platte herabzuschwenken, so daß das Verriegelungselement (8) des Streifens (6) der ersten Platte in der Verriegelungsnut (14) der neuen Platte aufgenommen wird,

oder

den Unterschritt, die neue Platte in einer zweiten Reihe, der ersten Reihe benachbart, anzuordnen, wobei der Verriegelungsstreifen (6), der an einer langen Kante (3) der neuen Platte vorgesehen ist, unter die benachbarte, lange Kante (4) der ersten Platte eingeführt wird, die mit einer Verriegelungsnut (14) versehen ist, während die neue Platte unter einem Winkel in bezug auf eine Hauptebene der ersten Platte und mit einem Abstand von ihrer endgültigen Längsposition in bezug auf eine vorhergehend verlegte, zweite Platte in der zweiten Reihe gehalten wird, und

den Unterschritt, nachfolgend die neue Platte herabzuschwenken, so daß das Verriegelungselement (8) des Streifens (6) der ersten Platte in der Verriegelungsnut (14) der neuen Platte aufgenommen wird,

und

- S2: mechanisches Verbinden einer kurzen Kante der neuen Platte mit einer kurzen Kante der vorhergehend verlegten, zweiten Platte in der zweiten Reihe derart, daß die neue Platte und die zweite Platte als Ergebnis des zweiten Hauptverriegelungsschritts S2 mechanisch miteinander an den kurzen Kanten (3', 4') in der ersten Richtung (D1) sowie in einer dritten Richtung (D3) parallel zu der Hauptebene und unter rechten Winkeln zu den kurzen Kanten (3', 4') verriegelt werden, wobei der zweite Hauptverriegelungsschritt S2 durch eine geradlinige Verschiebung der neuen Platte in ihrer Längsrichtung in bezug auf die erste Platte in die endgültige Längsposition ausgeführt wird, bis das Verriegelungselement (8) des Streifens (6') an einer (4') der kurzen Kanten in der Verriegelungsnut (14') an der anderen (4') der kurzen Kanten aufgenommen wird, wodurch die neue Platte in ihrer endgültigen, verlegten Position mechanisch in zwei Richtungen (D1, D2) an ihrer langen Kante mit der ersten Platte und in zwei Richtungen (D1, D3) an ihrer kurzen Kanten mit der zweiten Platte verbunden wird.
2. Verfahren wie in Anspruch 1 beansprucht, wobei als Ergebnis der geradlinigen Verschiebung der neuen Platte der Verriegelungsstreifen (6'), der sich an den kurzen Kanten (3', 4') befindet, die miteinander verriegelt werden sollen, nach unten gebogen wird, bis das Verriegelungselement (8) nach oben in die Verriegelungsnut (14') einschnappt.
 3. Verfahren wie in Anspruch 1 oder 2 beansprucht, wobei die kurze Kante (4') der neuen Platte, die mit der kurzen Kante (3') der zweiten Platte verriegelt werden soll, eine Verriegelungsnut (14') zum Eingriff mit einem Verriegelungselement (8) der zweiten Platte aufweist.
 4. Verfahren wie in Anspruch 3 beansprucht, wobei die neue Platte in eine Position herabgeschwenkt wird, in der der Endabschnitt der neuen Platte, der zu der zweiten Platte weist, auf und in Berührung mit dem Verriegelungsstreifen (6') an der kurzen Kante (3') der zweiten Platte angeordnet wird.
 5. Verfahren wie in Anspruch 1 oder 2 beansprucht, wobei die kurze Kante (3') der neuen Platte, die mit der kurzen Kante (4') der zweiten Platte verriegelt werden soll, einen Verriegelungsstreifen (6') mit einem Verriegelungselement (8) zum Eingriff mit einer Verriegelungsnut (14') der zweiten Platte aufweist.

6. Verfahren wie in irgendeinem der Ansprüche 1-5 beansprucht, wobei der Unterschnitt, die neue Platte herabzuschwenken durchgeführt wird, während ein oberer Eckenteil der langen Kante der neuen Platte mit einem oberen Eckenteil der langen Kante der ersten Platte in Berührung gehalten wird.
7. Verfahren gemäß irgendeinem der Ansprüche 1-6, wobei die neue Platte, nachdem sie verlegt und mit der ersten und der zweiten Platte mechanisch verbunden worden ist, aufgenommen werden kann, indem die neue Platte und die zweite Platte zusammen in bezug auf die erste Platte nach oben verschwenkt werden und nachfolgend die neue Platte von der zweiten Platte durch Verschwenken und/oder geradlinige Verschiebung der neuen Platte in bezug auf die zweite Platte gelöst wird.
8. Verfahren wie in Anspruch 7 beansprucht, wobei der Schritt, die neue Platte und die zweite Platte zusammen in bezug auf die erste Platte zu verschwenken, ausgeführt werden kann, während ein oberer Eckenteil der langen Kante der neuen Platte in Berührung mit einem oberen Eckenteil der langen Kante der ersten Platte gehalten wird.

Revendications

1. Procédé de pose et de raccordement mécanique de panneaux rectangulaires de construction (1, 2) en rangées parallèles, notamment de panneaux de plancher, les panneaux (1, 2) ayant un dispositif de blocage mécanique de leurs bords longs ainsi que de leurs bords courts dans une première direction (D1) perpendiculaire au plan principal des panneaux (1, 2), caractérisé en ce que chaque panneau (1, 2), à sa face arrière, possède (i) une bande de blocage (6, 6') placée à un premier bord long (3) et à un premier bord court (3'), chaque bande de blocage (6, 6') étant soit un élément séparé raccordé au panneau, soit un prolongement d'une partie inférieure du bord du joint (3, 3'), s'étendant pratiquement sur toute la longueur du bord correspondant (3, 3') et ayant un élément de blocage (8) qui dépasse de la bande (6, 6'), et (ii) une gorge de blocage (14, 14') placée à un long bord opposé (4) et à un court bord opposé (4') pour recevoir un élément de blocage (8) d'un panneau adjacent, chaque gorge de blocage (14, 14') s'étendant parallèlement au bord correspondant (4, 4') à distance de ce bord et étant ouvert à une face arrière du panneau, et en ce que le procédé comprend les deux étapes principales suivantes de blocage S1 et S2 pour la pose d'un nouveau panneau :

S1 : la connexion mécanique d'un bord long (4 ou 3) du nouveau panneau à un bord long (3

ou 4) d'un premier panneau déjà posé dans une première rangée de manière que le nouveau panneau et le premier panneau, à la suite de la première étape principale de blocage S1, soient bloqués mécaniquement l'un à l'autre dans la première direction (D1) ainsi que dans une seconde direction (D2) parallèle au plan principal et perpendiculaire aux bords longs bloqués (3, 4), la première étape de blocage principale S1 comprenant à cet effet :

- soit
- une sous-étape de mise en place du nouveau panneau dans une seconde rangée adjacente à la première rangée, le bord long (4) du nouveau panneau ayant une gorge de blocage (14) placée sur une bande de blocage (6) et au contact d'une telle bande à un long bord adjacent (3) du premier panneau, avec maintien du nouveau panneau suivant un angle par rapport au plan principal du premier panneau et à distance de la position longitudinale finale par rapport à un second panneau déjà posé dans la seconde rangée, et
- une sous-étape d'inclinaison ultérieure vers le bas du nouveau panneau afin qu'il loge l'élément de blocage (8) de la bande (6) du premier panneau dans la gorge de blocage (14) du nouveau panneau,
- soit
- une sous-étape de mise en place du nouveau panneau dans une seconde rangée adjacente à la première rangée, la bande de blocage (6) disposée à un bord long (3) du nouveau panneau étant introduite sous le bord long adjacent (4) du premier panneau qui a une gorge de blocage (14), avec maintien du nouveau panneau en formant un angle par rapport au plan principal du premier panneau et à une certaine distance de sa position longitudinale finale par rapport à un second panneau déjà posé dans la seconde rangée, et
- une sous-étape d'inclinaison ultérieure vers le bas du nouveau panneau afin qu'il loge l'élément de blocage (8) de la bande (6) du nouveau panneau dans la gorge de blocage (14) du premier panneau, et

S2 : la connexion mécanique d'un bord court du nouveau panneau à un bord court du second panneau déjà posé dans la seconde rangée de manière que le nouveau panneau et le second panneau, à la suite de la seconde étape principale de blocage S2, soient bloqués mécaniquement l'un sur l'autre au niveau des bords courts (3', 4') dans la première direction (D1) ainsi que

dans une troisième direction (D3) parallèle au plan principal et perpendiculaire aux bords courts (3', 4'), la seconde étape principale de blocage S2 étant exécutée par déplacement linéaire du nouveau panneau selon sa direction longitudinale par rapport au premier panneau vers ladite position longitudinale finale jusqu'à ce que l'élément de blocage (8) de la bande (6') à un premier (4') des bords courts soit reçu dans la gorge de blocage (14') à l'autre (4') des bords courts, si bien que le nouveau panneau, dans sa position finale posée, est connecté mécaniquement dans deux directions (D1, D2) à son bord long au premier panneau et dans deux directions (D1, D3) à son bord court au second panneau.

2. Procédé selon la revendication 1, dans lequel, à la suite du déplacement linéaire du nouveau panneau, la bande de blocage (6') placée aux bords courts (3', 4') afin qu'ils soient bloqués est courbée vers le bas jusqu'à ce que l'élément de blocage (8) s'enclenche élastiquement dans la gorge de blocage (14').
3. Procédé selon la revendication 1 ou 2, dans lequel le bord court (4') du nouveau panneau à bloquer sur le bord court (3') du second panneau présente une gorge de blocage (14') destinée à coopérer avec un élément de blocage (8) du second panneau.
4. Procédé selon la revendication 3, dans lequel le nouveau panneau est incliné vers le bas vers une position dans laquelle la partie d'extrémité du nouveau panneau tournée vers le second panneau est placée sur la bande de blocage (6') et au contact de celle-ci au bord court (3') du second panneau.
5. Procédé selon la revendication 1 ou 2, dans lequel le bord court (3') du nouveau panneau à bloquer sur le bord court (4') du second panneau présente une bande de blocage (6') ayant un élément de blocage (8) destiné à coopérer avec une gorge de blocage (14') du second panneau.
6. Procédé selon l'une quelconque des revendications 1 à 5, dans lequel l'étape secondaire d'inclinaison vers le bas du nouveau panneau est exécutée avec maintien d'une partie de coin supérieur du bord long du nouveau panneau au contact d'une partie de coin supérieur du bord long du premier panneau.
7. Procédé selon l'une quelconque des revendications 1 à 6, dans lequel le nouveau panneau, après sa pose et la formation de joints mécaniques avec le premier et le second panneau, peut être retiré par inclinaison du nouveau panneau et du second panneau ensemble vers le haut par rapport au premier

panneau puis par libération du nouveau panneau par rapport au second panneau par inclinaison et/ou déplacement linéaire du nouveau panneau par rapport au second panneau.

5

8. Procédé selon la revendication 7, dans lequel l'étape d'inclinaison du nouveau panneau et du second panneau ensemble par rapport au premier panneau peut être exécutée avec maintien d'une partie de coin supérieur du bord long du nouveau panneau au contact d'une partie de coin supérieur du bord long du premier panneau.

10

15

20

25

30

35

40

45

50

55

12

Fig. 3a

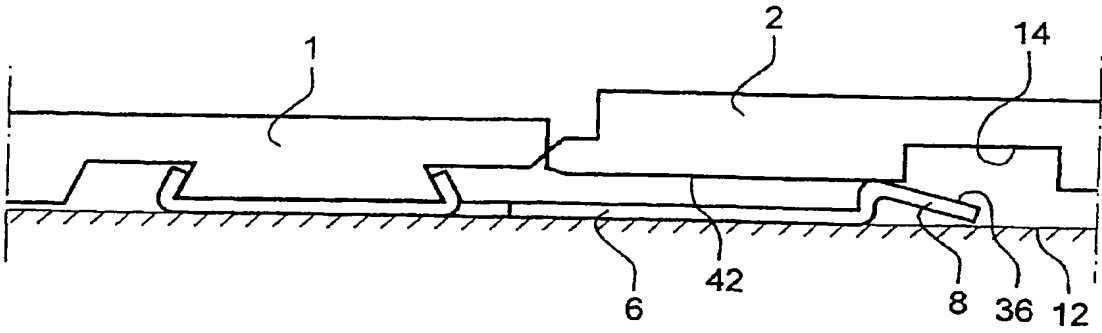

Fig. 3b

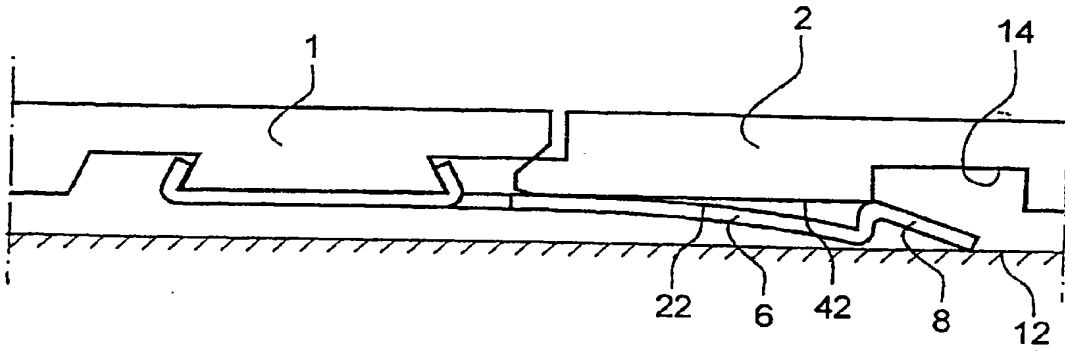

Fig. 3c

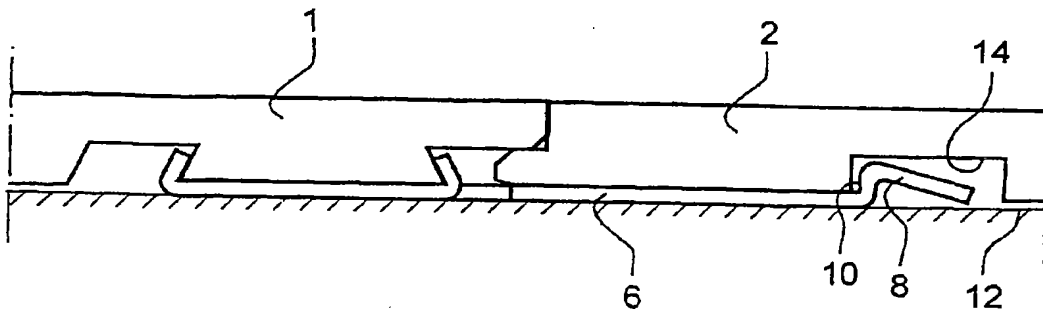

Fig. 4a

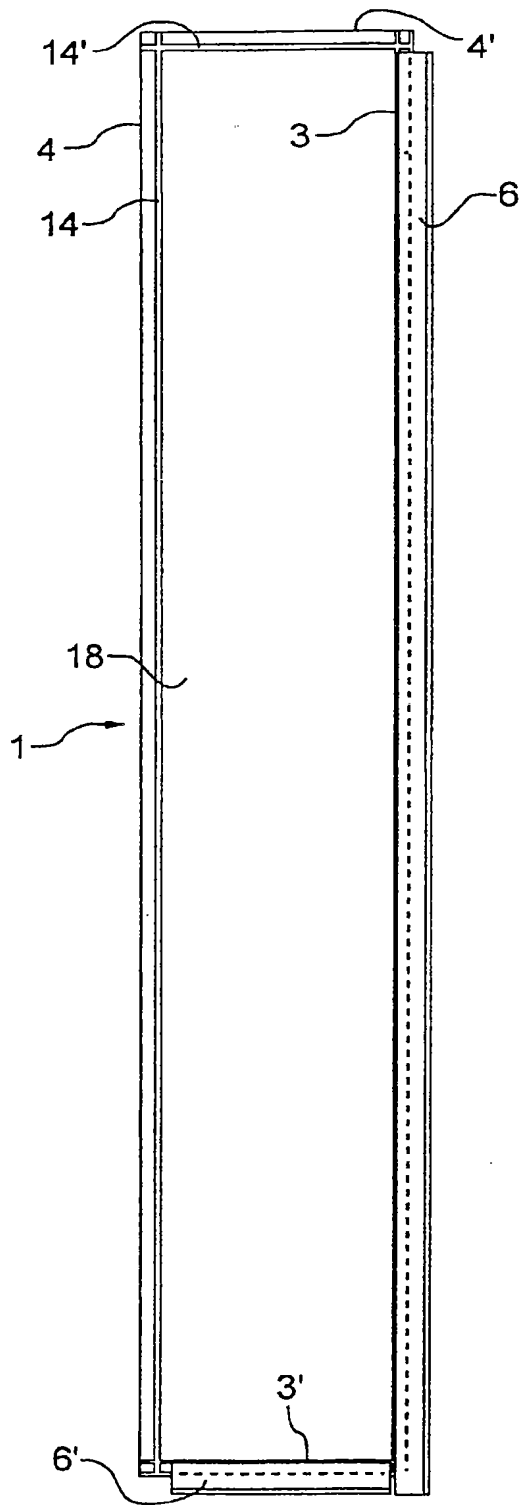

Fig. 4b

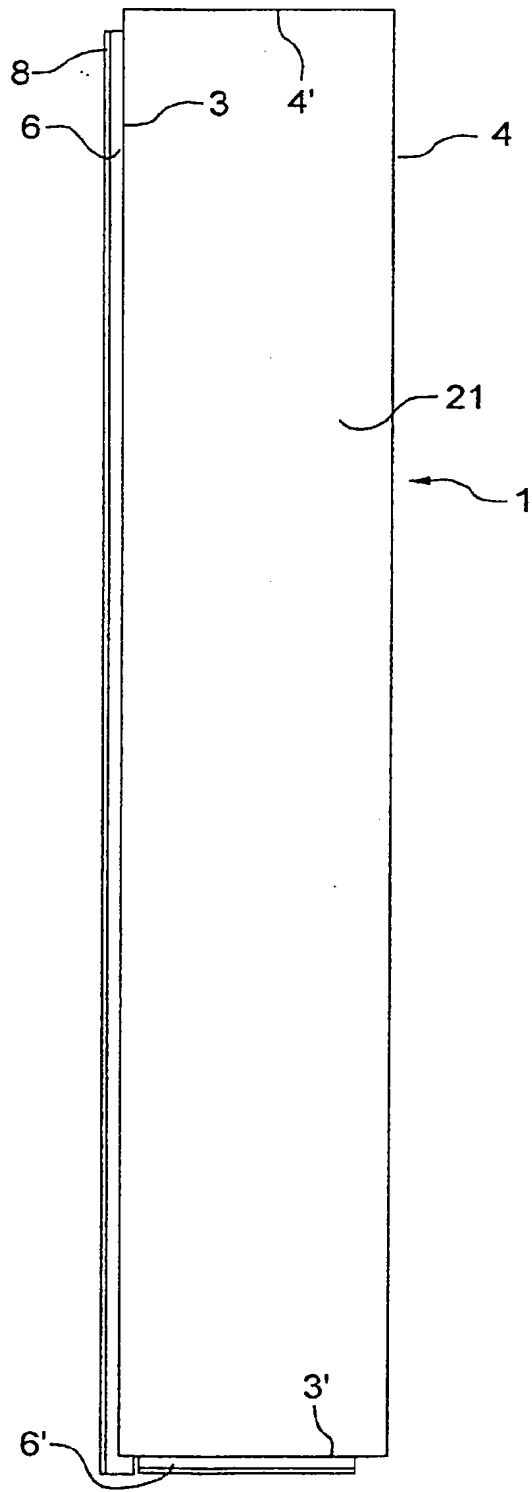

Fig. 5

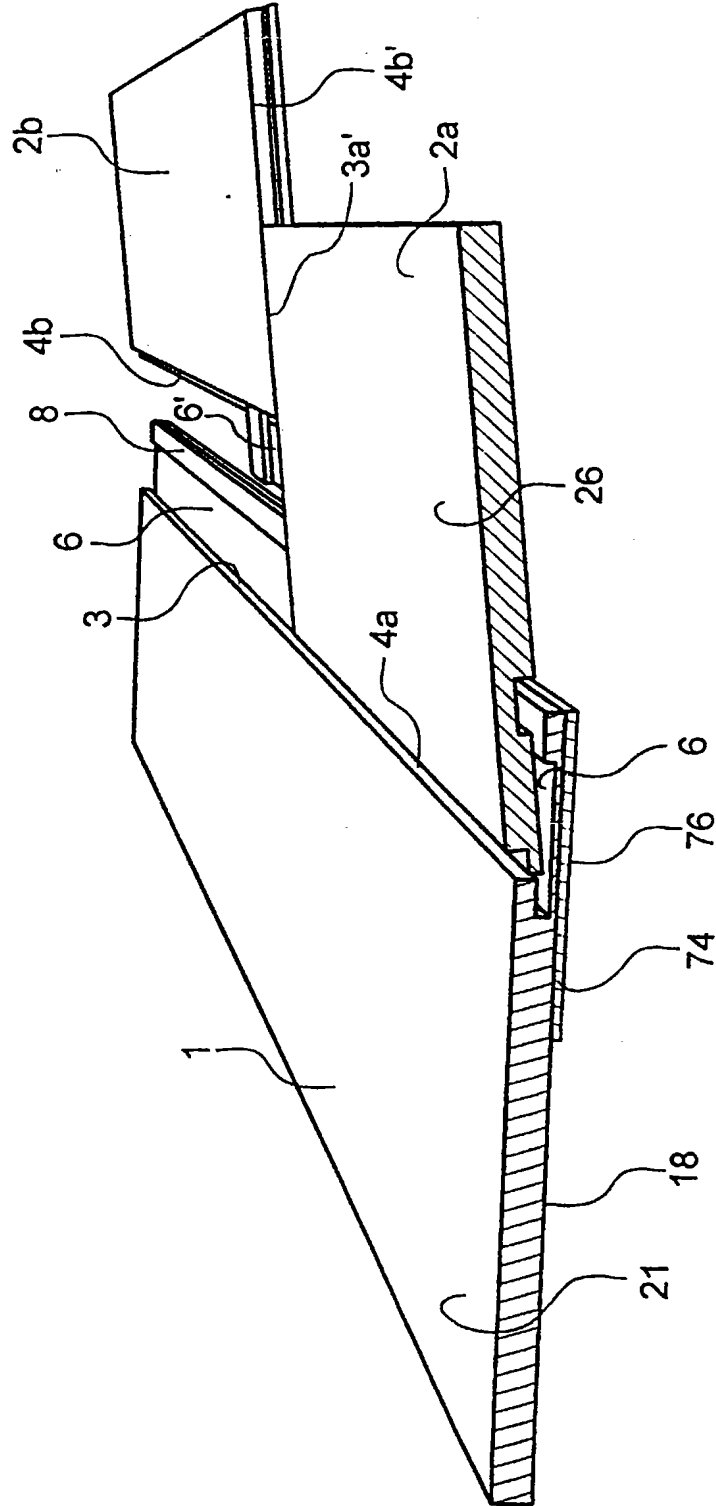

Fig. 6

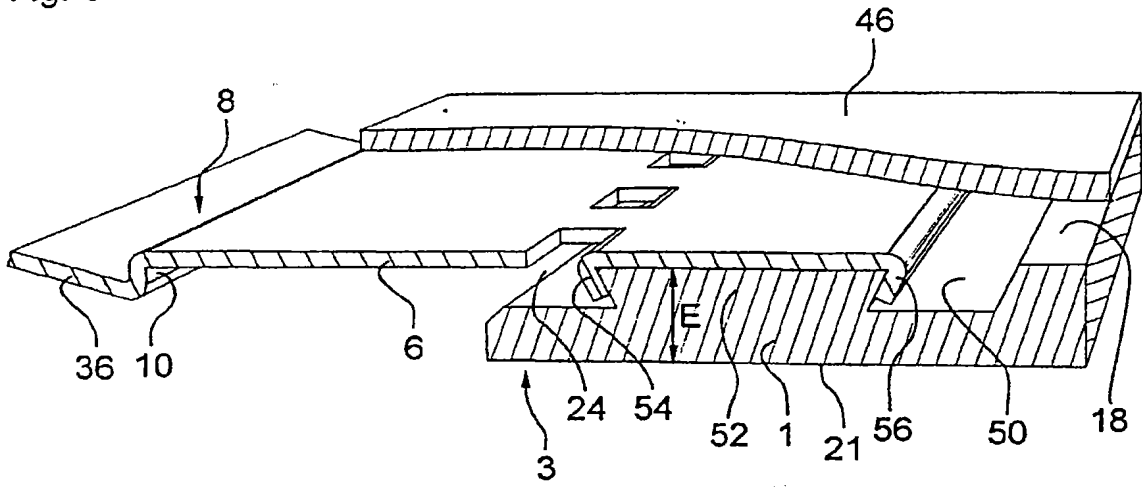
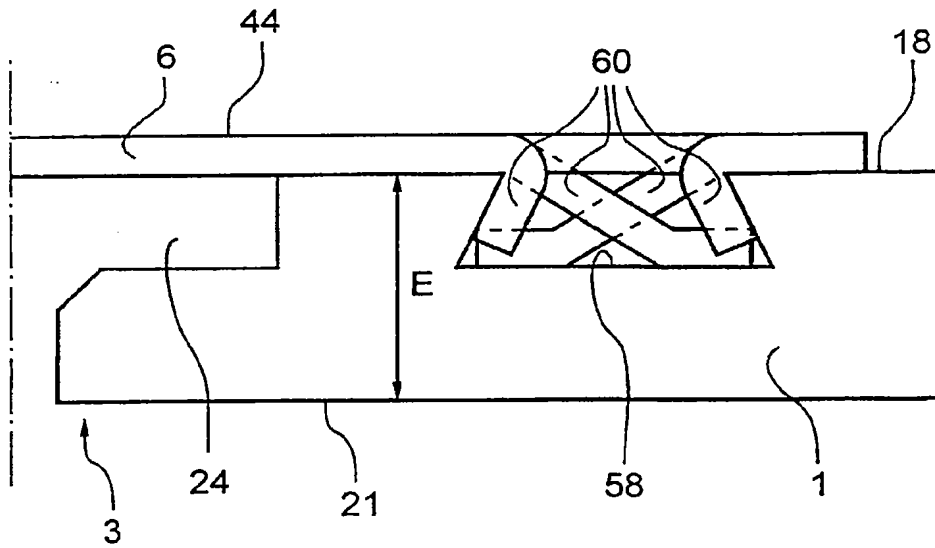

Fig. 7



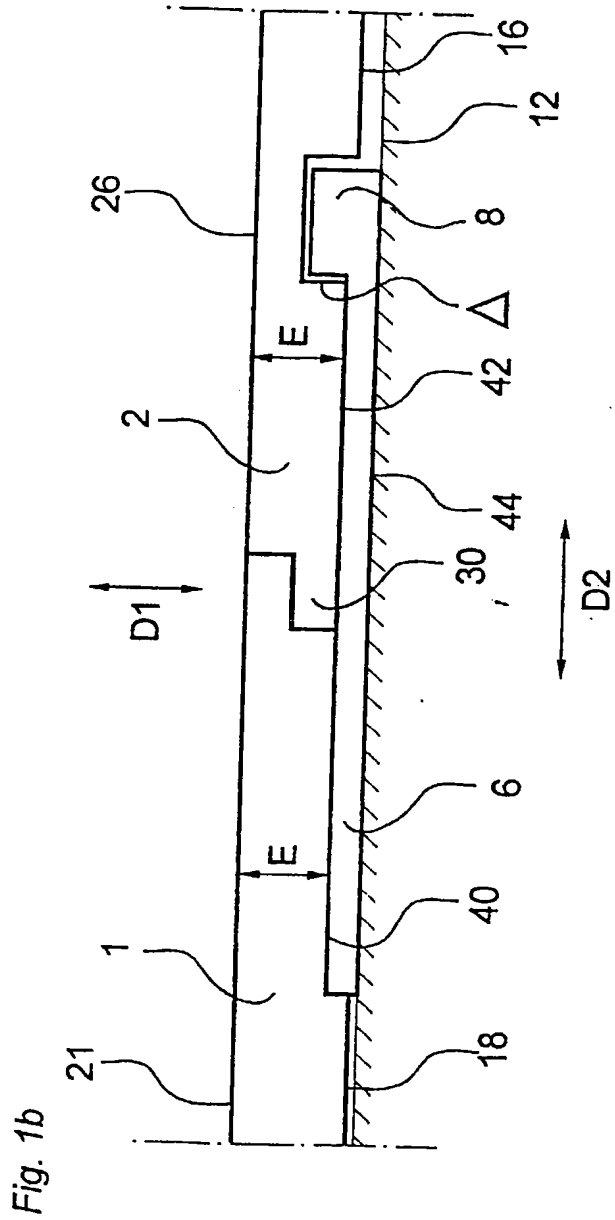
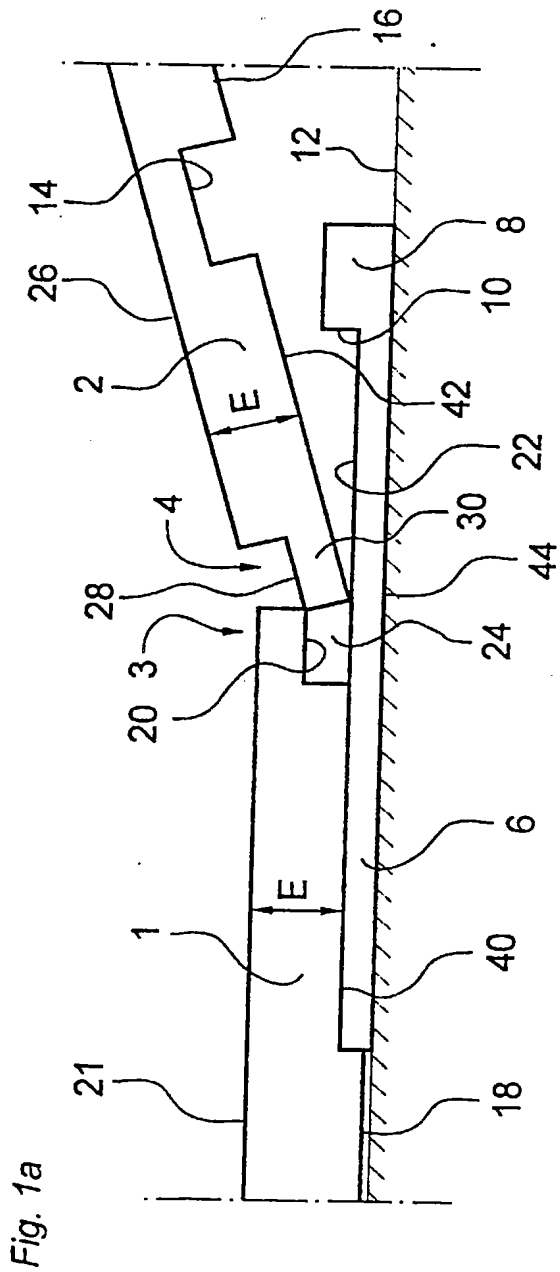

Fig. 2a

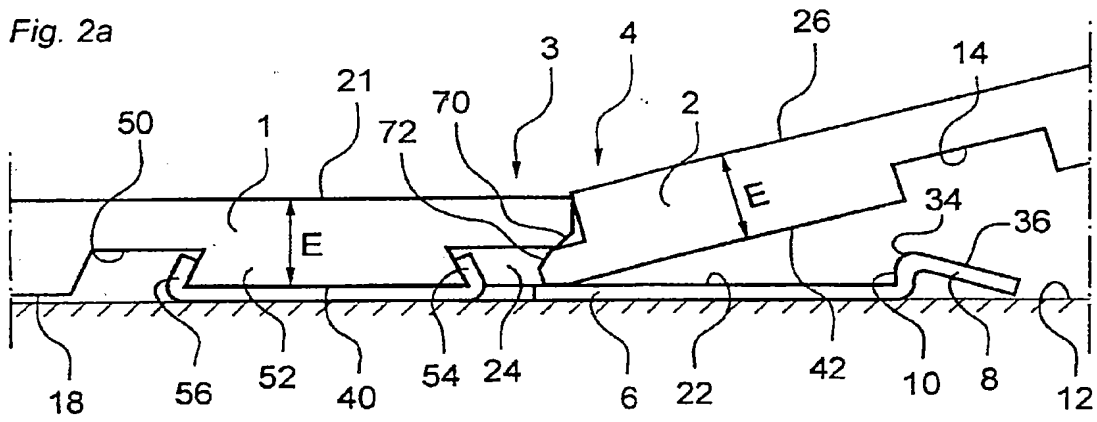

Fig. 2b

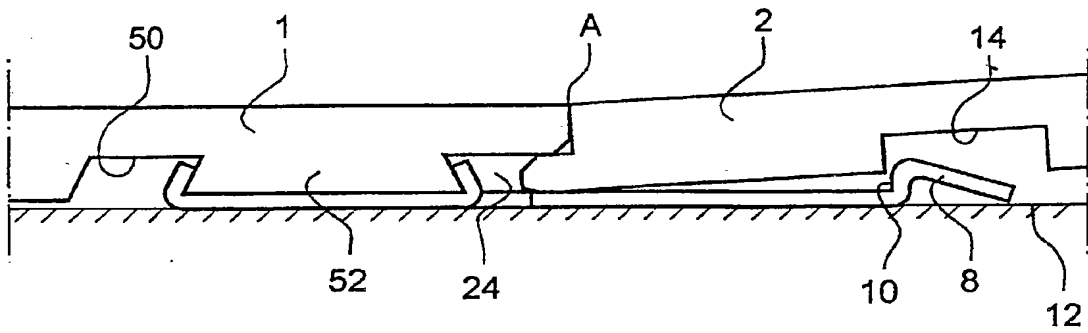

Fig. 2c

